

MATCHSTICK CANNON

Instructions - Matchstick Cannon

Read through the Instructions carefully before starting your Model.

Begin by cutting out the shapes shown by a dotted line.

The model you are making is a card structure onto which the matches are glued using a PVA Adhesive. The ruled areas show where to glue the matches and in which direction they should run. Before gluing, Score the lines indicated should there be a fold line, fold then flatten out before applying glue or matches.

When gluing the matches spread a small amount of glue along the edge of the card and lay a line of matches parallel to the guide lines. Press the matches firmly together and stagger the joins for strength as you build up rows of matches until the whole area is covered.

Use the safety cutter to cut matches to exact lengths or trim off any over hands with a craft knife.

Do not throw away any off cuts as these can be used to fill any gaps and/or small areas.

Do not glue together at dotted lines, glue to card only as this section would be required to fold.

Unless otherwise instructed, when matches are glued to both sides of the card shape they should run in opposite directions to give strength through the structure and prevent bending. Allow the first side to dry before applying the other side with glue and matches.

When the section has been glued it is best to place it under a heavy object to keep it flat while the glue dries, an old book would be an example.

When the section is dry, rub down any rough surfaces and edges with a sandpaper.

Once the model is complete and assembled a coat of varnish can be added to keep it looking its best.

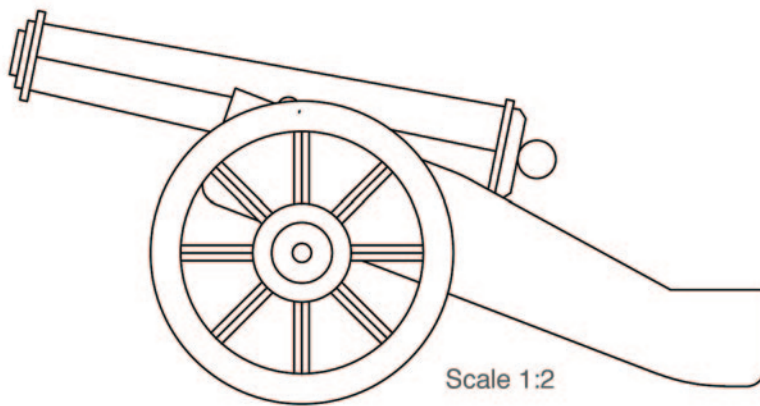

MATCHSTICK CANNON

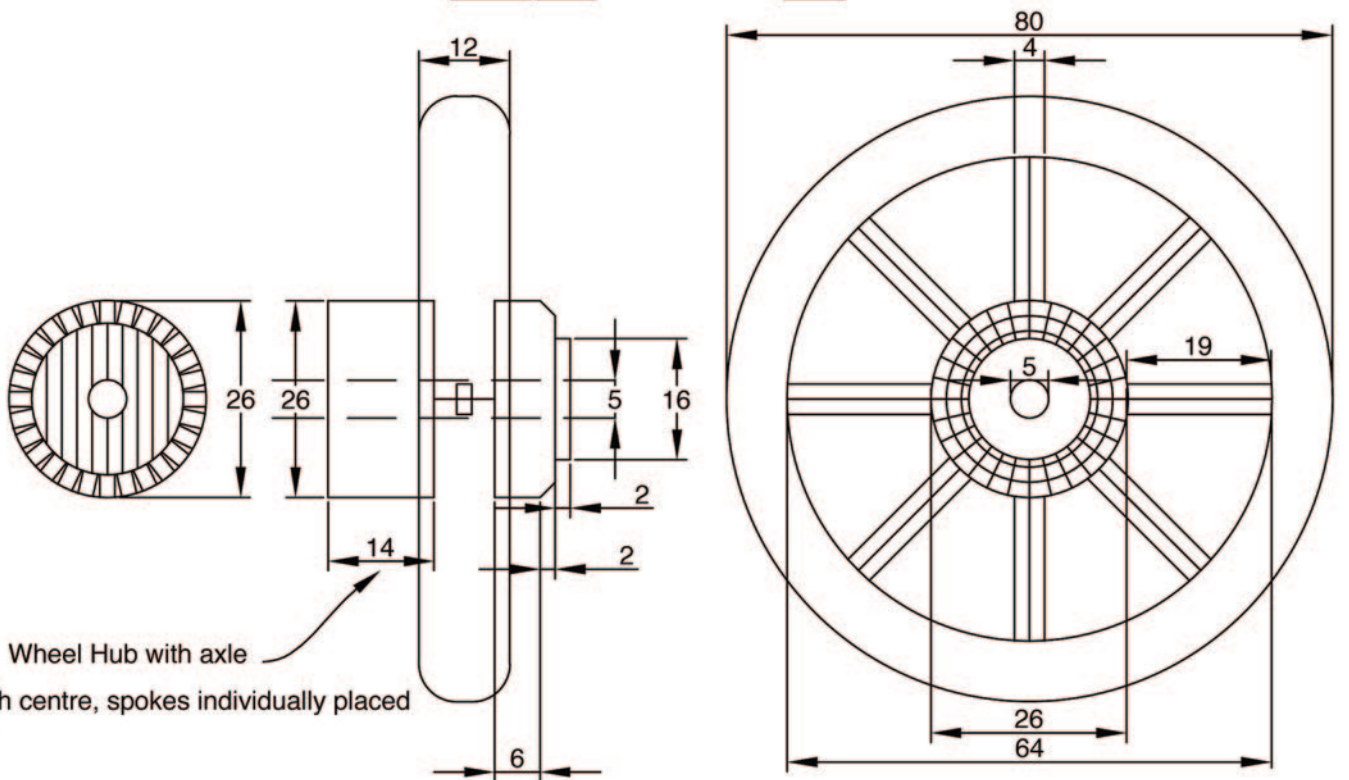
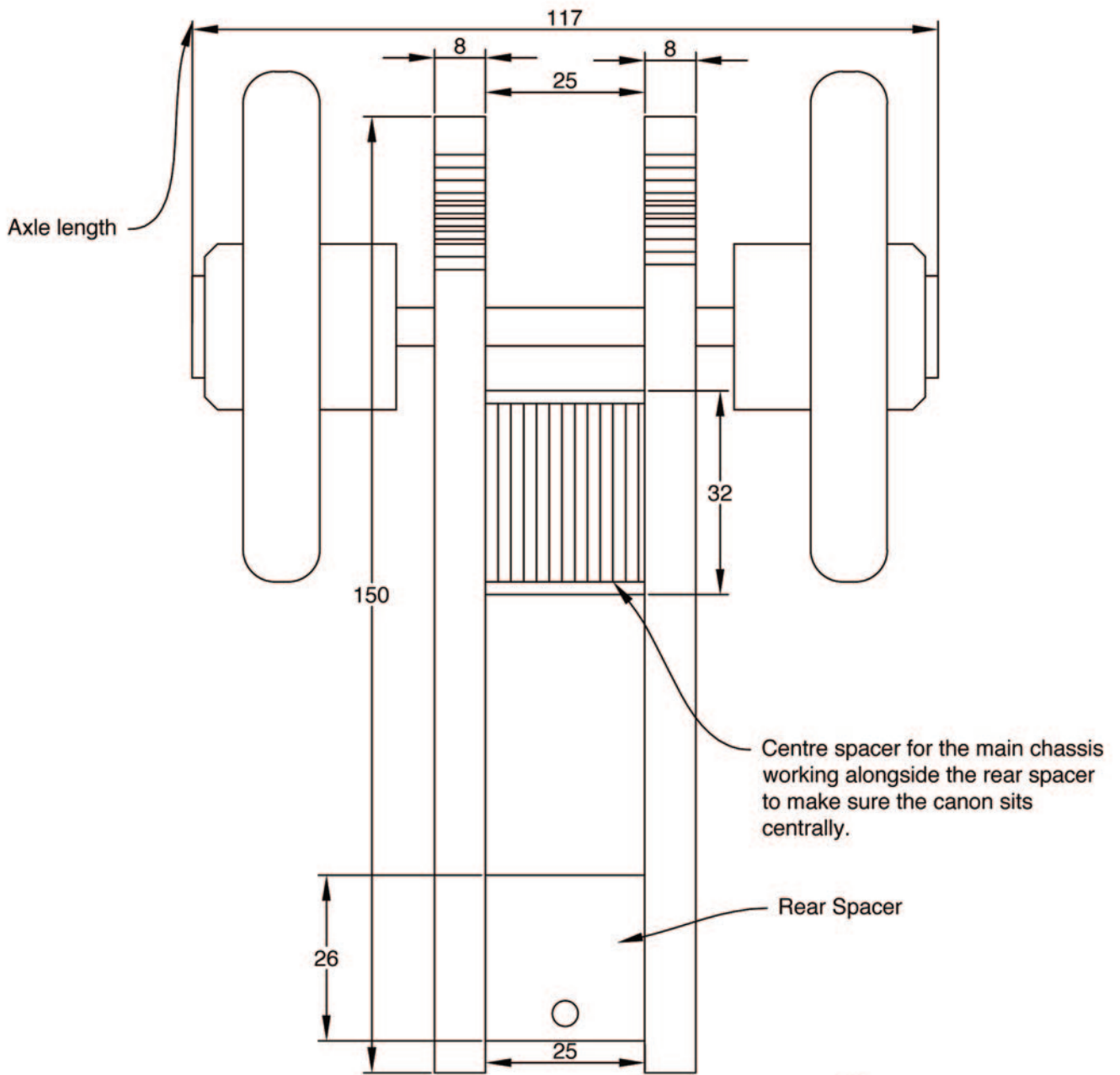

MATCHSTICK CANNON

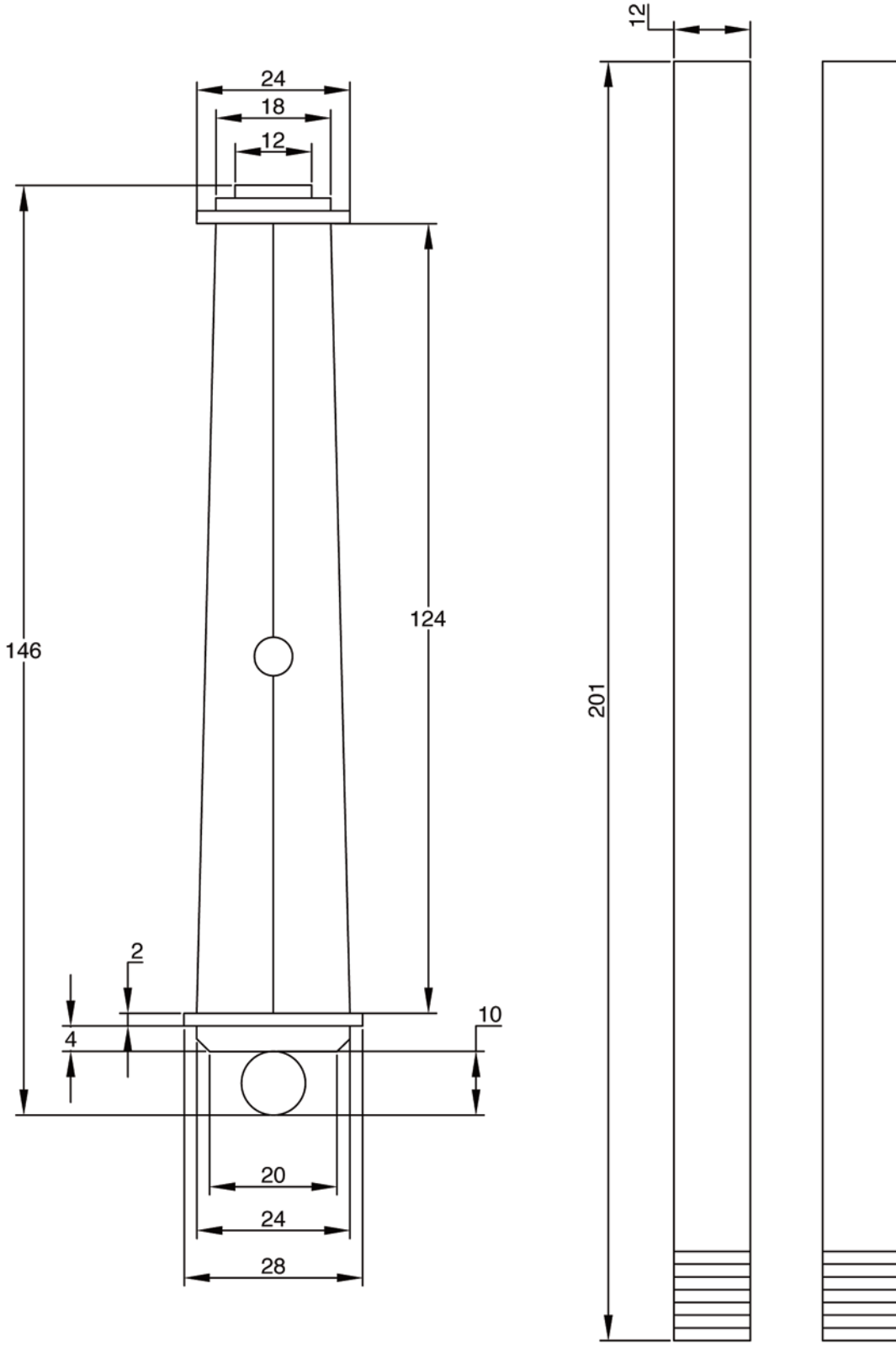

MATCHSTICK CANNON

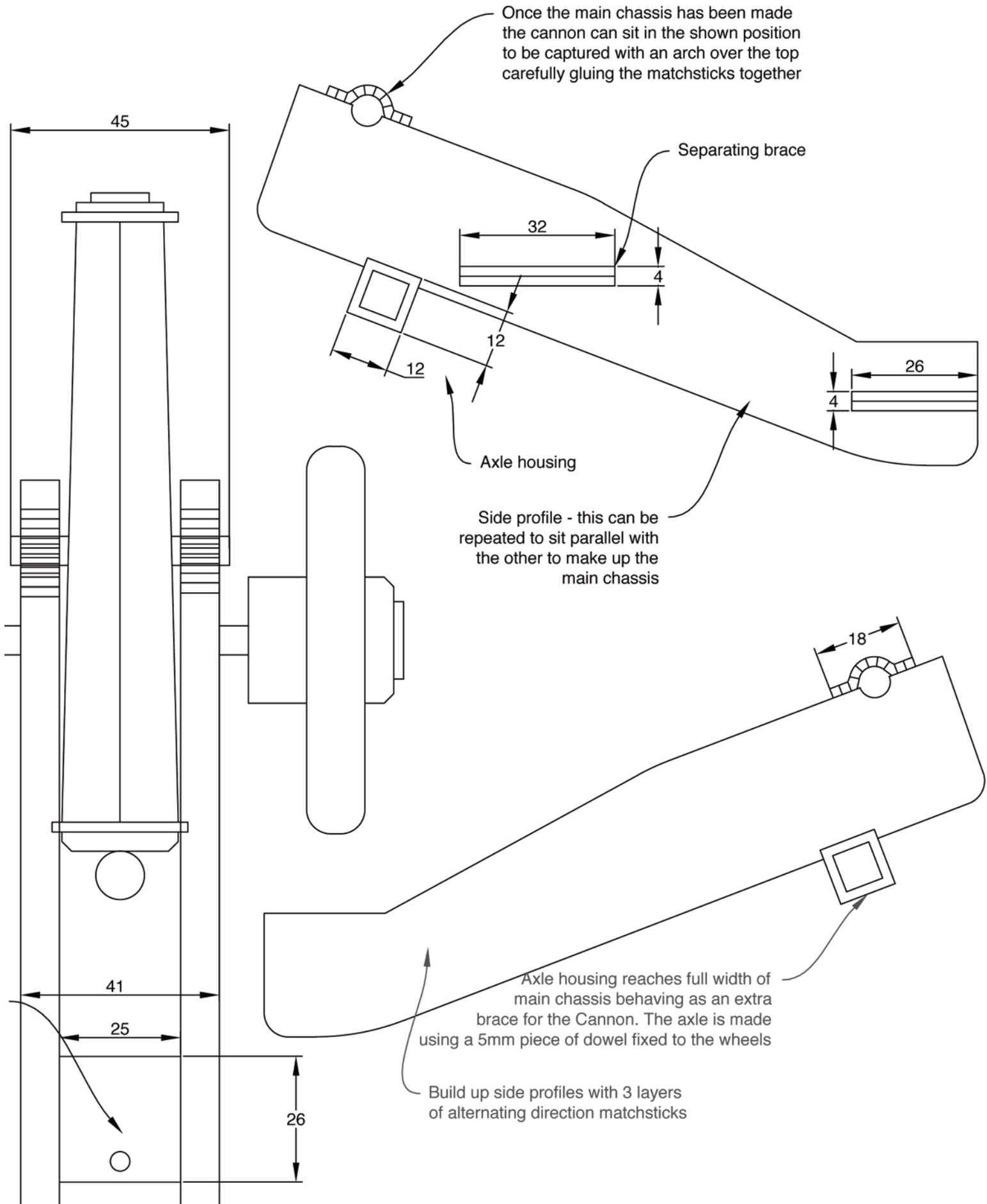

MATCHSTICK CANNON

